

RESEARCH ARTICLE



ISSN: 2321-7758

## IoT BASED DATA LOGGER SYSTEM FOR WEATHER MONITORING USING WIRELESS SENSOR NETWORKS

HONRAO S.B<sup>1</sup>, BHORE SNEHA N<sup>2</sup>.

<sup>1</sup>Lecturer, Department of E&TC Engineering, Aditya Engineering College, Beed, M.S. India.

<sup>2</sup>Student, Department of E&TC Engineering, Aditya Engineering College, Beed, M.S. India.



### ABSTRACT

The system proposed in this paper is an advanced solution for monitoring the weather conditions at a particular place and make the information visible anywhere in the world. The technology behind this is Internet of Things (IoT), which is an advanced and efficient solution for connecting the things to the internet and to connect the entire world of things in a network. Here things might be whatever like electronic gadgets, sensors and automotive electronic equipment. The system deals with monitoring and controlling the environmental conditions like temperature, relative humidity, light intensity and CO<sub>2</sub> level with sensors and sends the information to the web page and then plot the sensor data as graphical statistics. The data updated from the implemented system can be accessible in the internet from anywhere in the world.

**Keywords:** Internet of Things, Wi-Fi, Wireless Sensors

©KY Publications

### I. INTRODUCTION

The importance of weather monitoring is existed in many aspects. The weather conditions are required to be monitored to maintain the healthy growth in crops and to ensure the safe working environment in industries, etc. Due to technological growth, the process of reading the environmental parameters became easier compared to the past days. The sensors are the miniaturized electronic devices used to measure the physical and environmental parameters. By using the sensors for monitoring the weather conditions, the results will be accurate and the entire system will be faster and less power consuming.

The system proposed in this paper describes the implemented flow of the weather monitoring station. It includes the wireless communication technology IEEE 802.11 b/g which is also familiar as Wi-Fi in general terms. The system

monitors the weather conditions and updates the information to the web page. The reason behind sending the data to the web page is to maintain the weather conditions of a particular place can be known anywhere in the world. The system consists of temperature sensor, Co2 sensor, Humidity sensor and light dependent resistor. All this sensors can measure the corresponding weather parameter. The system is intended to use in large residential buildings and manufacturing industries. The system is including with a microcontroller to process all the operations of the sensors and other peripherals. The wireless communication standard was chosen in our system by analysing the requirements of the application, that the weather conditions should be monitored and updated all the time continuously. There are many local area network standards for communication, but they are all standalone communication processes and completely localized

communication. In our application, we have to make the weather condition of a particular place can be informative anywhere worldwide. The other communication technologies like Zig Bee, RF Link can make the communication nearly in the same range of Wi-Fi but they can't broadcast the information as they can only communicate peer to peer. The World Wide Web (www) needs to have one client – server configuration for communication. It client needs to be connected to the server with its IP address which can be universally accessible.

The system is equipped with all sensor devices should acts as client to send the data to the web server. For establishing a connection between the sensor network and internet, we used a Wi-Fi module as an additional communication interface controlled by the microcontroller. A Wi-Fi module requires a source of wireless internet connection. Once configuring the Wi-Fi module with an internet source, it acts as client and sends the sensor data retrieved by the microcontroller. The criteria of connecting all the sensors to the internet is Internet of Things (IoT). The concept of connecting the electronic devices, sensors, and automobile equipment together via internet.

#### A. Internet of Things (IoT)

It is the future technology of connecting the entire world at one place. All the objects, things and sensors can be connected to share the data obtained in various locations and process/analyses that data for coordinating the applications like traffic signalling, mobile health monitoring in medical applications and industrial safety ensuring methods, etc. As per the estimation of technological experts, 50 billion objects will be connected in IoT by 2020. IoT offers a wide range of connectivity of devices with various protocols and various properties of applications for obtaining the complete machine to machine interaction.

The traditional technologies like home automation, wireless sensor networks and control systems will become more efficient and smarter due to involvement of IoT. IoT is having a wide range of application areas. Such as Medical applications for monitoring the health of a patient and sends the information wireless. The present developing

Wearable instrumentation is also based on IoT. The example wearable instrumentation is Smart wrist bands, navigation pills, etc. All this methods require an internet interface to update the health info or to control the device with a smart phone. The IoT also plays a vital role in media applications for advertising and exchanging the information worldwide. The manufacturing processes also requires IoT for supply chain management, digital control systems for monitoring the manufacturing processes.

The space requirements of IoT technology, the geographical specifications are always important in case of tracking applications. The geographical dimensions of objects is also important while obtaining the data from the objects. IoT in automobile applications and traffic maintenance became a most using area of automation. The automated devices in a vehicle should be connected to a cloud to update the car health within a period of time. By connecting the vehicles and traffic signalling systems to the internet, people can easily find the shortest path for their destination from the traffic monitoring systems and can navigate automatically by checking all other directions.

#### II. LITERATURE SURVEY

The survey has firstly done on wireless technologies to establish a Wireless sensor network. Study went on choosing the suitable wireless technology. It should be suitable in all aspects like economic and technological. The primary concern we have to make while choosing the communication method is range of communication. Here we have chosen 802.11b/g Wi-Fi. When we are giving an internet source, the data can be exchanged anywhere in the world through its IP address. The further study has done on selecting the microcontroller. The system implementation is contained with a hidden goal of achieving low power consumable solution. The microcontroller should be also low power consuming alongside all the remaining sensors also low power consuming. We have chosen LPC2148 which is low power microcontroller and works with only 3.3v.

The next study went on the data logger methods on web page. The data collected from the

sensors is mostly in the form of integer values representing the value of environmental parameter. The web page displaying the data of sensors directly will not make a simpler impression for the users. It should be in a graphical representation for easy understanding of the users. The data hosted on an own web page will be more expensive and have to pay for it in a rental basis. To make the system less expensive, we preferred some free data hosting web sites who provides a cloud space for our sensor data to make it universal and also makes the system less expensive.

### III. SYSTEM ARCHITECTURE

The implemented system consists of a microcontroller (LPC2148) as a main processing unit for the entire system and all the sensor and devices can be connected with the microcontroller. The sensors can be operated by the microcontroller to retrieve the data from them and it processes the analysis with the sensor data and updates it to the internet through Wi-Fi module connected to it.

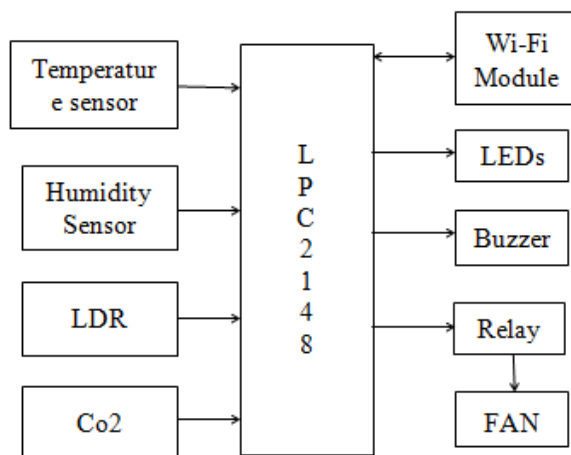

Fig.1 Block Diagram

In the above block diagram, there it is showing the main elements in the proposed system.

1) *LPC2148* : The microcontroller used in this system LPC2148 is an effective choice for the implemented system. As our proposed system is a low power consumable solution, the microcontroller should be also low power consuming. LPC2148 is having 8 channel Analog to Digital converter which will be a major advantage with this microcontroller to get the data from the analog sensors connected to it. It is having so many features on chip.

2) *Wi-Fi Module*: Here we used ESP8266 Wi-Fi module which is having TCP/IP protocol stack integrated on chip. So that it can provide any microcontroller to get connected with Wi-Fi network. ESP8266 is a preprogrammed SOC and any microcontroller have to communicate with it through UART interface. It works with a supply voltage of 3.3v. The module is configured with AT commands and the microcontroller should be programmed to send the AT commands in a required sequence to configure the module in client mode. The module can be used in both client and server modes.

Once it gets connected in a Wi-Fi network, we'll get one IP address which is accessible in its local network. The module is additionally having 2 GPIO pins alongside UART pins. It is also having inbuilt SPI protocol by using the two pins of UART as data lines and by configuring the two GPIO pins as control lines and clock signal. It is also having 1MB on-chip flash memory. Internally it is having power management unit with all regulators and PLLs. The on-chip processor it is having is a 32 bit CPU.



Fig.2 ESP8266 Pin Details

3) *Sensors*: The system consists of temperature sensor, humidity sensor, LDR and CO2 sensor. This 4 sensors will measure the primary environmental factors light intensity, temperature, CO2 levels and relative humidity respectively. All these sensors will give the analog voltage representing one particular weather factor. The microcontroller will convert this analog voltage into digital data.

4) *LEDs*: The Light Dependent Resistor will monitor the light intensity of the surrounding environment. If the light intensity is getting low then automatically the LED lights will glow with a required intensity. Using the LED bulbs will save the energy in homes and industries. Here

we are controlling the intensity of the LEDs based on the outside light, so that we can save more power. Relay: Relay is used to perform the switching actions for the AC/DC devices. In the proposed system, relay is used to switch the cooling fan. Whenever the room temperature is getting higher than the limit, then the cooling fan will be ON automatically through relay.

#### IV. SOFTWARE IMPLEMENTATION

In the proposed system, the software implementation plays a major role while retrieving the sensor data and updating it to the server. Here two software tools we used mainly. They are, Keil uVision Ide and Flash Magic.

The Keil uVision IDE is an embedded programming platform which supports various microcontrollers and provides a complete programming environment for the microcontrollers. We used this IDE for programming the LPC2148 which is a microcontroller with ARM7 TDMI processor.

Flash magic is a tool used for writing the machine language code into the microcontroller's flash memory. This tool also facilitates the additional features like terminal window for the hardware devices. The entire programming part of the system can be done in C language.

Firstly, we have to initialize the ESP8266 by sending a few AT commands. Initialization process includes, checking the communication with ESP8266 to microcontroller, searching for a Wi-Fi network within its range and connecting the Wi-Fi module to that network by getting authenticated with required credentials. After the initialization process, we have to program for configuring the Wi-Fi module as a TCP/IP client. While configuring the ESP8266, checking the acknowledgment is important to ensure that the module is configured correctly.

After configuring the ESP8266, we have to program for reading the sensor data. The ADC (Analog to Digital Converter) unit should configure with all prerequisites like clock frequency, resolution and data format. Then the microcontroller will run the instruction continuously to get the updated data values from sensors. Now the major task has arrived in discussion, i.e. plotting the sensor data in

a graphical form. Here we need to go through some kind of a networking environment, where we need to deal with IP address communication.

As we mentioned in the earlier chapters, we used one open source data logger web site to make reduce the implementation cost. In a normal way, if we want to plot the data into web site, we have to own and pay for the domain space and design the web page as per our requirements, which is complex and costlier method. Instead of paying for a own domain, we used one web site called "Thingspeak". It provides a free user space for creating the data channels. Each channel will be having 8 fields to write the various data and it automatically plots the given data in a graphical representation. The communication with Thingspeak server can be done by using its IP address. We have to program for ESP8266 to send the required AT commands and to establish a connection between the system and Thingspeak server.

Once we created once channel for entering the data into web site, the channel will be allocated with one API key. So we have to write the API key before writing the actual data, then the data will be stored and displayed in the required channel.

In this proposed system, we have created one Thingspeak channel and used 4 fields in it. The four fields can store. The actual data obtained from the sensors will be first stored in a script and then the Thingspeak server will automatically plots the data retrieving from the field which we have entered an integer data of sensor output.

#### V. SYSTEM FUNCTIONALITY

The system functionality includes the working process of the entire system after integrating all the peripherals along with software. The system works in three phases, one is reading the data from the sensors, and another one is sending the data to the "Thingspeak" server and finally controlling the devices as per the data obtained.

The system can also performs the controlling tasks for an immediate action regarding the sensor output. Initially the Wi-Fi module will be configured in client mode, then the sensors will be monitored and read by the microcontroller. The

temperature sensor and LDR will give the values continuously which is required to control the fan and light based on the values. If the temperature is increased upon the range, immediately fan will be ON to control the temperature. And if the light is getting dark, immediately, the LED bulbs will be ON. Similarly the remaining two sensors also monitored and updated continuously, but the humidity and Co2 are the rare factors in the weather consideration, so we are reading the data from this two sensors when it is getting high or low than the predefined limit.

can be updated once for 15 seconds. It can't be updated more than one time within a time span of 15 seconds. So it will not be a problem while reading the data from the sensors.

All the analog sensors any how takes time for reading the physical parameter and process it. So 15 seconds is a pretty enough time for updating a field of sensor values.

The entire working flow of the system is shown in the diagram (Fig 6).

#### VI. CONCLUSION

The research and implementation of a system for monitoring the environmental parameters using IoT scenario is accomplished. The system provides a low power solution for establishing a weather station. The system is tested in an indoor environment and it is successfully updated the weather conditions from sensor data. It is also a less expensive solution due to usage of low power wireless sensors and SoC contained Wi-Fi module.

#### REFERENCES

- [1]. "Indoor air facts no. 4 (revised) sick building syndrome",1991[online] Available:[http://www.epa.gov/iaq/pdfs/sick\\_building\\_factsheet.pdf](http://www.epa.gov/iaq/pdfs/sick_building_factsheet.pdf)
- [2]. S. Sharma, V. N. Mishra, R. Dwivedi and R. R. Das "Quantification of individual gases/odors using dynamic responses of gas sensor array with ASM feature technique", *IEEE Sensors J.*, vol. 14, no. 4, pp.1006 -1011 2014
- [3]. Xively. *Xively Is the Public Cloud Specifically Built for the Internet of Things.*, [online] Available: [https://xively.com/whats\\_xively/](https://xively.com/whats_xively/)
- [4]. H. Yang, Y. Qin, G. Feng and H. Ci "storage and leakage based on wireless sensor networks", *IEEE Sensors J.*, vol. 13, no. 2, pp.556 -562 2013 and *Temperature Transmitter 3008-40-V6*
- [5]. *Sensor Moves Into Volume Production.*, [online] Available: <http://www.enocean-alliance.org/en/gss-seamless-sensingco2-sensor-moves-into-volume-production>
- [6]. V. Jelicic, M. Magno, D. Brunelli, G. Paci and L. Benini "Context-adaptive multimodal

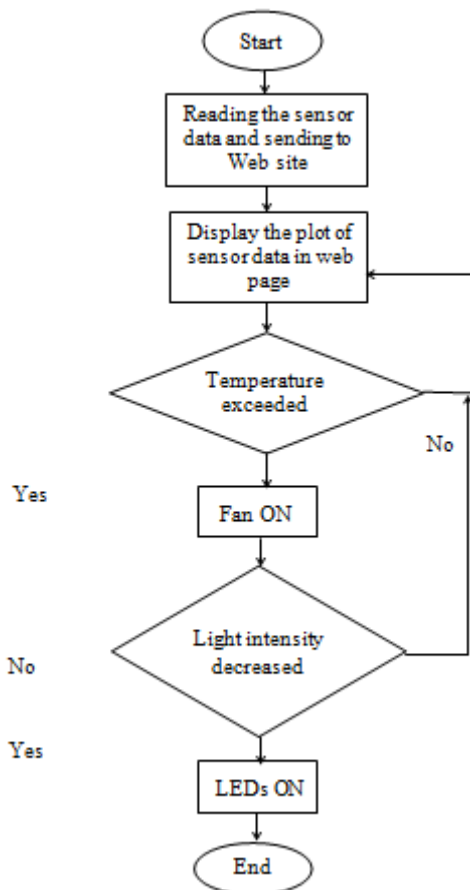

Fig. 6 Flow Diagram

For example, if the relative humidity in the air is more 35 degree Celsius, sensor gives the data as logic 1 (High) otherwise logic 0 (Low). In the same way, Co2 sensors also gives the data 1 or 0 based on Co2 levels in air. The obtained sensor values will be sent to the Thingspeak server and a plot can be drawn in the channel by considering the given sensor values as Y axis and time and date as X axis. The only limitation in updating the values is one field

- wireless sensor network for energy-efficient gas monitoring", *IEEE Sensors J.*, vol. 13, no. 1, pp.328 -338 2013
- [7]. *Programmable System-on-Chip(PSoC)*, 2014 [online]Available:<http://www.cypress.com/?docID=49257>
- [8]. *RN-131G & RN-131C 802.11 b/g Wireless LAN Module.*,2012[online]Available:<http://www.rovingnetworks.com>
- [9]. S. S. Shrestha "Performance evaluation of carbon-dioxide sensors used in building HVAC applications", 2009[online] Available:<http://lib.dr.iastate.edu/etd/10507>
- [10]. T. Sanislav and L. Miclea "An agent-oriented approach for cyber-physical system with dependability features", *Proc. IEEE Int. Conf. Autom. Quality Testing Robot(AQTR)*, pp.356 -361
- [11]. F.-J. Wu,Y.-F. Kao and Y.-C. Tseng "From wireless sensor networks towards cyber physical systems", *Pervasive Mobile Comput.*, vol. 7, no. 4, pp.397 -413 2011
- [12]. S. Tozlu, M. Senel, W. Mao and A. Keshavarzian "Wi-Fi enabled sensors for internet of things: A practical approach", *IEEE Commun. Mag.*,vol. 50, no. 6, pp.134 143 2012
-