



DESIGN AND ANALYSIS OF MASTER CYLINDER OF HYDRAULIC BRAKING SYSTEM

C. RAGHUNATH REDDY¹, Dr. V. NAGA PRASAD NAIDU², S SARDAR ALI³

¹M.Tech Scholar, Mech Dept, Intell Engineering College, Anantapuram.

²Professor & Principal, Intell Engineering College, Anantapuram.

³Head of Mechanical Engg. Dept, Intell Engineering College, Anantapuram.



**C. RAGHUNATH
REDDY**

ABSTRACT

In recent years more importance is given to methods to reduce weight of an automobile and to reduce fuel consumption engine, chassis, and braking system and their shape optimization is the goal. For reducing the size of any automobile individual component shape to be optimized by reducing its size, weight and different parameters. In the present work design and analysis of master cylinder of hydraulic braking system. The master cylinder is designed with Pro-E and analyzed with analysis to reduce its size. The demand for a reduction in brake pedal effort and movement, without losing any of the sensitivity and response to the effective braking of vehicles, has led to the adoption of vacuum booster assisted units as parts of the braking system for most vehicles. These units convert the induction the brake fluid on the output side of the master cylinder.

In this work, master cylinder of the braking system will modeled and analyze using advanced software. The analysis will do by changing the cross-section of cylinder and stiffness of spring. By varying the above parameters, the shape of the cylinder will optimize. The goals of the structural analysis will to visualize the stress distribution, load application, deformation under static loads. The results will compare with strength of an existing system.

KEYWORDS: Master Cylinder Design, pro-E, Structural Analysis, Varying Parameters

©KY Publications

BRAKING SYSTEM

Brakes are used to slow down or stop the vehicle. Most brakes commonly use friction between two surfaces pressed together to convert the kinetic energy of the moving object into heat, though other methods of energy conversion may be employed. Hydraulic brakes are generally used in automobiles, where brakes are applied by pressure on a fluid.

Mechanical brakes are also used in some vehicles. These brakes are operated by means of levers, linkages, pedals, cams, etc. Hand brake or parking brake is usually a mechanical brake. These are used for parking the vehicles on sloppy surfaces and also in case of emergency.

Brakes are generally applied to rotating axles or wheels, but may also take other forms such as the

surface of a moving fluid (flaps deployed into water or air). Some vehicles use a combination of braking mechanisms, such as drag racing cars with both wheel brakes and a parachute, or airplanes with both wheel brakes and drag flaps raised into the air during landing.

IMPORTANT OF BREAKING SYSTEMS:

The brake system of your vehicle is by far the most important safety system that it has. Being able to slow down or stop at a moment's notice will help to avoid an incident or accident. Improperly working brakes will not do the job they are designed to do and will not be as effective when needed, especially in a panic stop situation.

Brakes should be regularly inspected, we recommend having your trusted repair facility regularly test drive the vehicle to see how the brake system functions. Then also perform an actual visual inspection, measuring pad and shoe thickness, check for even wear of the pads and shoes, check rotors for run out and hot spots, check hardware to make sure it is working properly and that it is adjusted properly. Make sure the wheel cylinders, brake lines and brake master cylinder are not leaking, inspect calipers for wear, free movement and fluid leaks, and check the level and condition of the brake fluid. Inspect for proper routing and placement of the brake and antilock brake sensors.

All of these components need to be in good shape and working properly for the vehicle to have 100% brake system effectiveness while driving. For instance, something that seems simple is the brake fluid, it can get contaminated over time with absorption of moisture and copper, this can decrease the effectiveness of the hydraulics within your brake system causing a less responsive brake pedal to the touch or feel, therefore causing a slight delay or reduction in braking power.

TYPES OF BREAKING SYSTEMS:

Brakes may be broadly described as using friction, pumping, or electromagnetic. One brake may use several principles: for example, a pump may pass fluid through an orifice to create friction:

1) Frictional brakes are most common and can be divided broadly into "shoe" or "pad" brakes, using an explicit wear surface, and hydrodynamic

brakes, such as parachutes, which use friction in a working fluid and do not explicitly wear. Typically the term "friction brake" is used to mean pad/shoe brakes and excludes hydrodynamic brakes, even though hydrodynamic brakes use friction. Friction (pad/shoe) brakes are often rotating devices with a stationary pad and a rotating wear surface. Common configurations include shoes that contract to rub on the outside of a rotating drum, such as a band brake; a rotating drum with shoes that expand to rub the inside of a drum, commonly called a "drum brake", although other drum configurations are possible; and pads that pinch a rotating disc, commonly called a "disc brake". Other brake configurations are used, but less often. For example, PCC trolley brakes include a flat shoe which is clamped to the rail with an electromagnet; the Murphy brake pinches a rotating drum, and the Ausco Lambert disc brake uses a hollow disc (two parallel discs with a structural bridge) with shoes that sit between the disc surfaces and expand laterally. A drum brake is a vehicle brake in which the friction is caused by a set of brake shoes that press against the inner surface of a rotating drum. The drum is connected to the rotating roadwheel hub.

The disc brake is a device for slowing or stopping the rotation of a road wheel. A brake disc (or rotor in U.S. English), usually made of cast iron or ceramic, is connected to the wheel or the axle. To stop the wheel, friction material in the form of brake pads is forced mechanically, hydraulically, pneumatically or electromagnetically against both sides of the disc. Friction causes the disc and attached wheel to slow or stop.

2) Pumping brakes are often used where a pump is already part of the machinery. For example, an internal-combustion piston motor can have the fuel supply stopped, and then internal pumping losses of the engine create some braking. Some engines use a valve override called a Jake brake to greatly increase pumping losses. Pumping brakes can dump energy as heat, or can be regenerative brakes that recharge a pressure reservoir called a hydraulic accumulator.

3) **Electromagnetic brakes** are likewise often used where an electric motor is already part of the machinery. For example, many hybrid gasoline/electric vehicles use the electric motor as a generator to charge electric batteries and also as a regenerative brake. Some diesel/electric railroad locomotives use the electric motors to generate electricity which is then sent to a resistor bank and dumped as heat. Some vehicles, such as some transit buses, do not already have an electric motor but use a secondary "retarder" brake that is effectively a generator with an internal short-circuit. Related types of such a brake are eddy current brakes, and electro-mechanical brakes (which actually are magnetically driven friction brakes, but nowadays are often just called "electromagnetic brakes" as well).

Electromagnetic brakes slow an object through electromagnetic induction, which creates resistance and in turn either heat or electricity. Friction brakes apply pressure on two separate objects to slow the vehicle in a controlled manner.

Master cylinder:

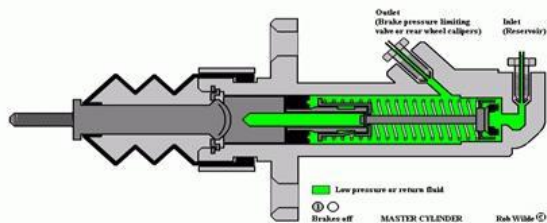

Fig: 1.6 Master cylinder

Master cylinder is a component of hydraulic braking system and it is just a simple piston inside a cylinder. Master cylinder is the key element of braking system which initiates and controls the braking action. A reservoir is attached to the master cylinder to store brake fluid. A master cylinder having a reservoir and a cylinder formed from a single piece of molded material. Master cylinder is a component of hydraulic braking system and it is just a simple piston inside a cylinder. Master cylinder is the key element of braking system which initiates and controls the braking action. A reservoir is attached to the master cylinder to store brake fluid. A master cylinder having a reservoir and a cylinder formed

from a single piece of molded material. The master cylinder displaces hydraulic pressure to the rest of the brake system. It holds the most important fluid in your car, the brake fluid. It actually controls two separate subsystems which are jointly activated by the brake pedal. This is done so that in case a major leak occurs in one system, the other will still function. The two systems may be supplied by separate fluid reservoirs, or they may be supplied by a common reservoir. Some brake subsystems are divided front/rear and some are diagonally separated. When you press the brake pedal, a push rod connected to the pedal moves the "primary piston" forward inside the master cylinder. The primary piston activates one of the two subsystems. The hydraulic pressure created, and the force of the primary piston spring, moves the secondary piston forward. When the forward movement of the pistons causes their primary cups to cover the bypass holes, hydraulic pressure builds up and is transmitted to the wheel cylinders. When the brake pedal retracts, the pistons allow fluid from the reservoir(s) to refill the chamber if needed. Electronic sensors within the master cylinder are used to monitor the level of the fluid in the reservoirs, and to alert the driver if a pressure imbalance develops between the two systems. If the brake light comes on, the fluid level in the reservoir(s) should be checked. If the level is low, more fluid should be added, and the leak should be found and repaired as soon as possible.

Master cylinders are available in brake fluid and mineral base hydraulic oil models with bore diameters from 0.75 to 2.25 inches and stroke ranges of 1.12 to 2.61 inches. Side and flange mounting styles are available. Most models are available with or without a residual check valve. Those are:

- Straight Bore Master Cylinders
- Two-Stage Master Cylinders
- Boosted Master Cylinders
- Hydraulic, Air, & Mechanical Actuated Master Cylinders

1) **Straight Bore Master Cylinder:** Straight Bore Master Cylinders are single piston, straight-bore type with a return spring, and are available with or without an integral reservoir. Most cylinders are available as brake fluid or mineral base hydraulic oil models and in a variety of mounting styles.



Fig: 1.7 Straight Bore Master Cylinder

2) **Two-Stage Master Cylinder:** Two-stage Master Cylinders are integrally designed to incorporate the advantage of a large piston for fluid volume and a small piston for high pressure. Transfer from the volume piston to the pressure piston is accomplished by means of a metered pressure relief valve. Two-stage master cylinders are commonly used on equipment that require larger volumes than provided by conventional master cylinders.



Fig.: 1.8 two stage master cylinder

3) **Boosted Master Cylinder:** Boosted master cylinders are designed for use in machines that are equipped with other hydraulic power devices. This design feature eliminates the need for a separate system to provide power for the boosted master cylinder. Boosted Master Cylinders are used on machinery that requires higher pressures than typically provided by master cylinders or two-stage master cylinders.



Fig: 1.9 Boosted master cylinder

4) **Hydraulic, Air, & Mechanical Actuated Master Cylinders:** Air chamber sizes are available from 12 to 36 square inches and hydraulic displacement from 1.0 to 5.9 cubic inches. Both remote and integral reservoir models are available for mineral base hydraulic oil or brake fluid. Remote Actuators are typically used to actuate a brake or clutch from two locations when two master cylinders are used. They prevent the transfer of fluid from one system to another system. The actuators are available in hand, foot, or hydraulically operated models. They can be used in combination with a remote reservoir to accommodate accessibility. Pressure intensifiers are ideal for applications where a low pressure hydraulic source is available and a small displacement of high pressure hydraulic fluid is required. These actuators are available in a number of lever, pedal, and hydraulic operated models.

5) **Air/Hydraulic Actuator:**



Fig: 1.10 Air /Hydraulic cylinder

6) **Working of Master Cylinder:** When the brakes are not applied, the piston cups of the primary and secondary pistons are positioned between the inlet port and the compensating port. This provides a passage between the cylinder and reservoir tank. The secondary piston is pushed to the right by the force of secondary return spring, but prevented from going any further by a stopper bolt. When the brake pedal is depressed, the primary

piston moves to the left. The piston cup seals the compensating port blocking the passage between the primary pressure chamber and the reservoir tank. As the piston is pushed further, it builds hydraulic pressure inside the cylinder and is applied or transmitted to the wheel cylinders in that circuit. The same hydraulic pressure is also applied to the secondary piston. Hydraulic pressure in the primary chamber moves the secondary piston to the left also. After the compensating port of the secondary chamber is closed, fluid pressure builds and is transmitted to the secondary circuit.

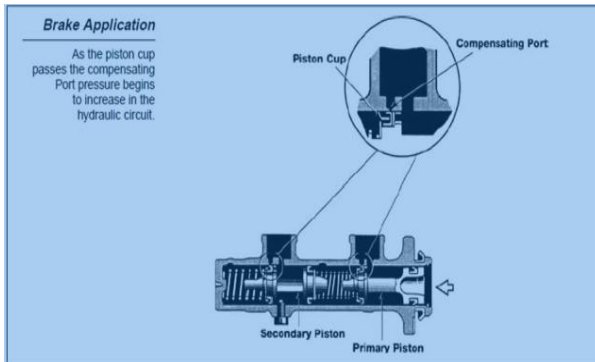

Fig:1.11 Working of master cylinder-brake application

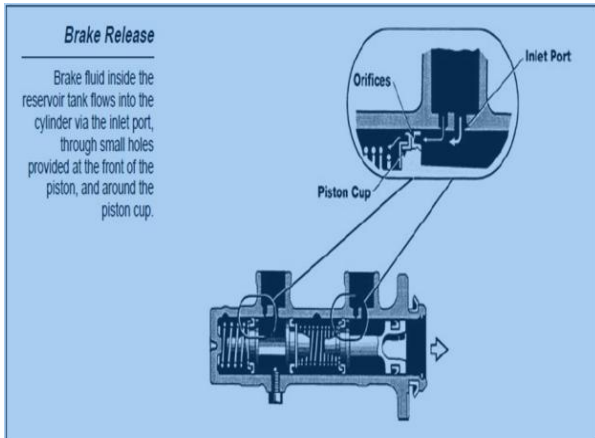

Fig: 1.12 Working of master cylinder-brake release

Automobiles or vehicles can be classified on different bases as given below : Here a heat sink (aluminum) with heat pipe (copper) with temperature difference transfers thermal energy within the effective temperature range i.e 100°C to 300°C .

The latent heat of evaporation absorbed by the vaporization of the working fluid reduces the temperature at the hot end of the pipe.

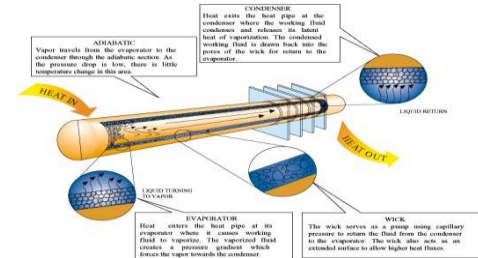

Fig. 2: Wick working phenomenon
 CHEMICAL INTERMEDIATE

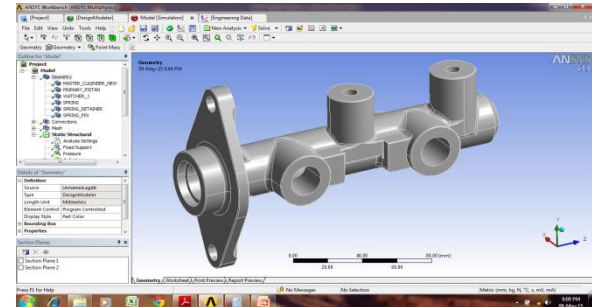

Fig: Geometry Import

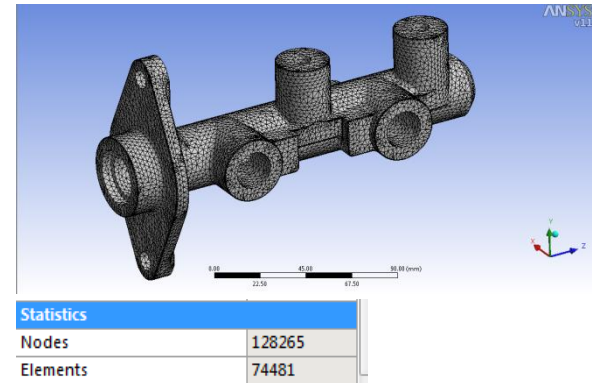

Fig: Mesh Generation

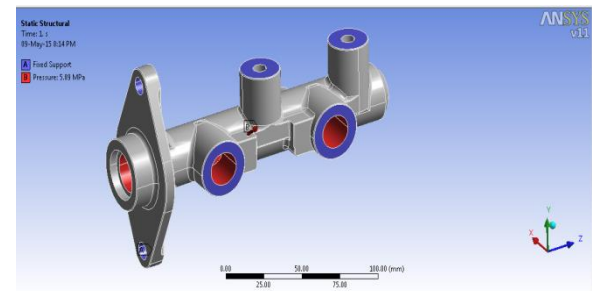

Fig: Solid Generation from mesh

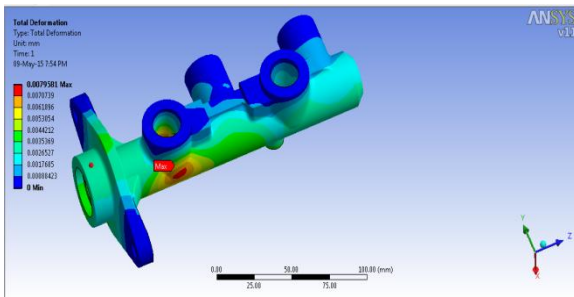

Fig: Total Deformation

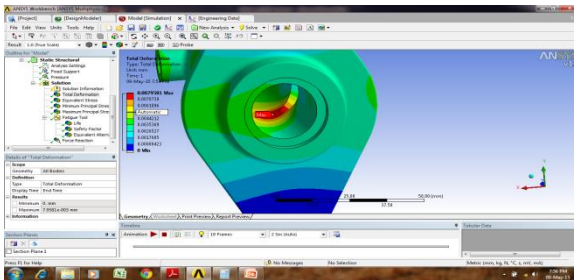

Fig: Total Deformation

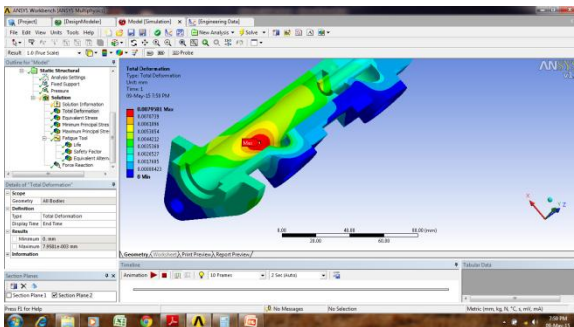

Fig: Total Deformation at the cut section

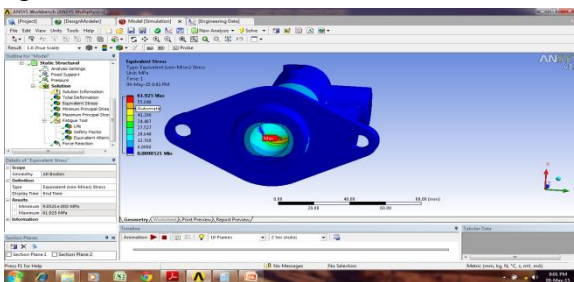

Fig: Equivalent stress

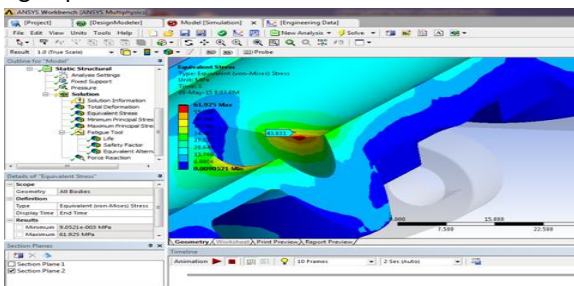

Fig: Equivalent stresses at cut section.

CASE 2: Cylinder 25 mm:

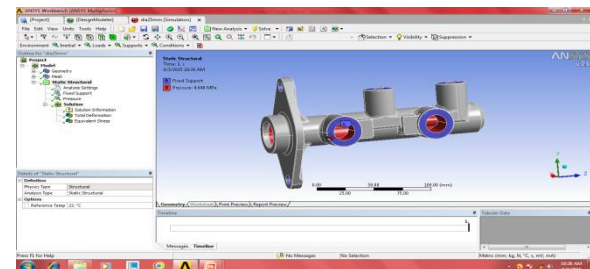

Fig: Pressure and Forced support application

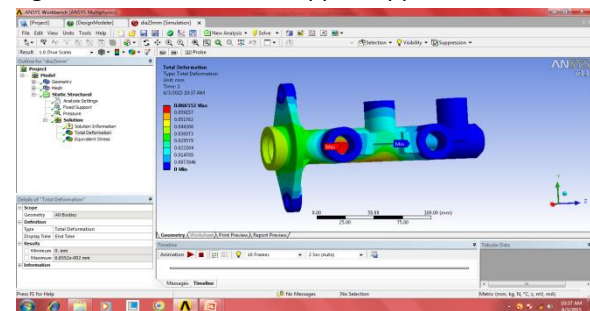

Fig: Total Deformation

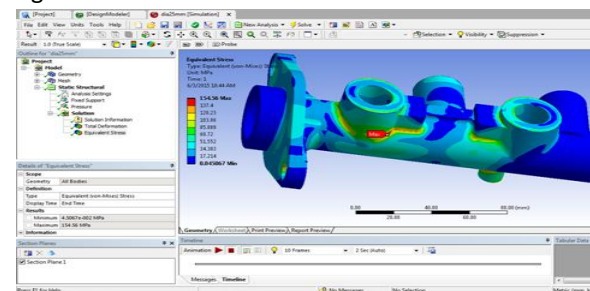

Fig: Equivalent stress

CASE 3: CYLINDER DIAMETER: 20 mm

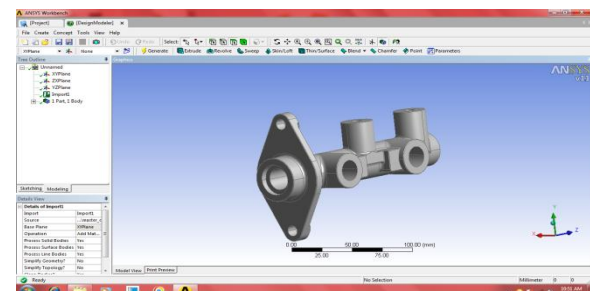

Fig: Geometry

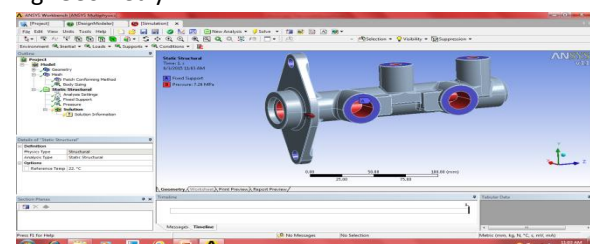

Fig: Pressure and fixed support application

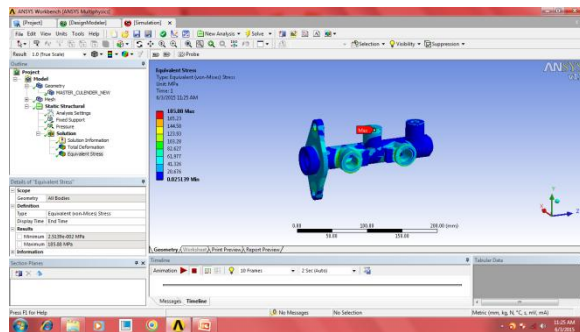

Fig: Equivalent stress

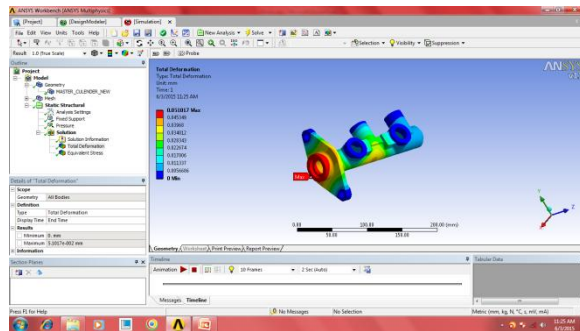

Fig: Total Deformation

TITANIUM ALLOY

Density :4.62e-06 kg / mm³,

Young's Modulus :96000 Mpa

Poisson's Ratio :0.36

Ultimate tensile stress :1070 N/mm²

CASE 1: CYLINDER DIAMETER :22 mm

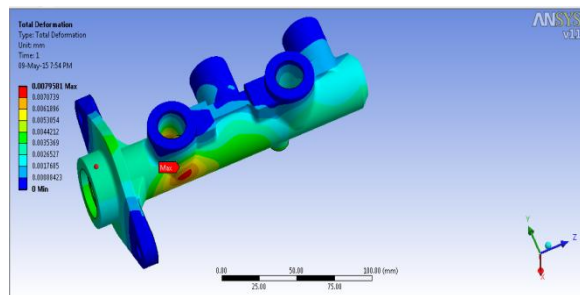

Fig: Total Deformation

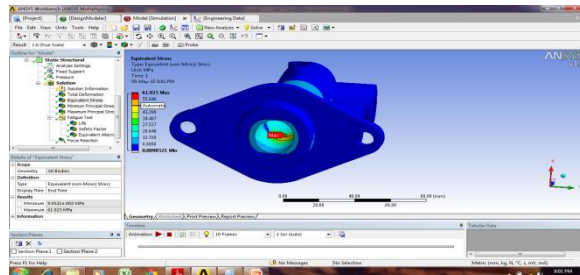

Fig: Equivalent stress

CASE 2: CYLINDER DIA : 25 mm

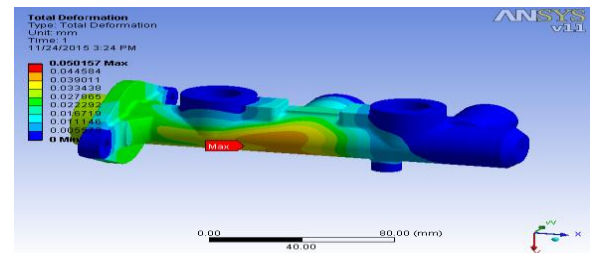

Fig: Total Deformation

CASE 3: CYLINDER DIA : 20 mm

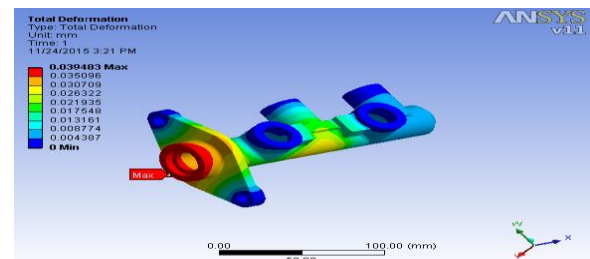

Fig: Total Deformation

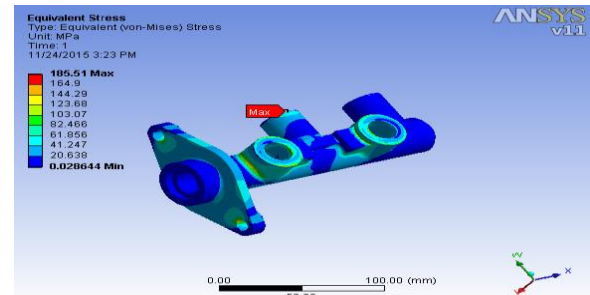

Fig: Equivalent stress

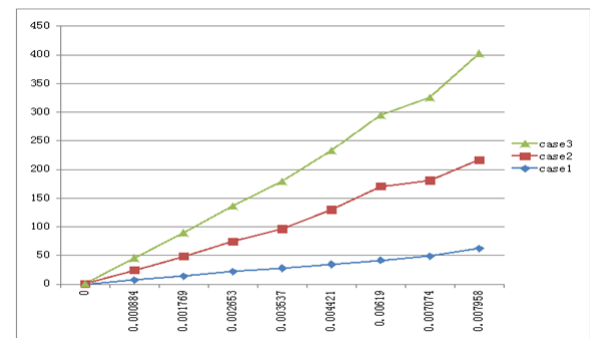

Fig: Graph : Pressure VS Diameter

RESULTS AND DISCUSSION

| Dia of Cylinder | Total deformation | | Equivalent stress | | Pressure |
|-----------------|-------------------|-------|-------------------|-------|----------|
| | Min | Max | Min | Max | |
| Al, 22.2 mm | 0 | 0.007 | 0.009 | 61.92 | |

| | | | | | |
|----------------------|---|-------|-------|--------|-------------|
| Titanium, 22.2 mm | 0 | 0.008 | 0.01 | 64.256 | 5.89 Mpa |
| Al, 20 mm | 0 | 0.051 | 0.025 | 185.88 | 7.26 Mpa |
| Titanium, 20 mm | 0 | 0.03 | 0.028 | 185.51 | |

For pressure 7.26 Mpa, applied at 20 mm of diameter the maximum stress acting on the surface of cast aluminium cylinder is 185.88 N/mm² and of titanium alloy is 185.51. Since the maximum stress acting on the surface of cylinder is very less compare to the ultimate strength of the material, so the 20 mm diameter size of cylinder can easily withstand the pressure. So we prefer 20 mm dia cylinder instead of 22.2 mm dia cylinder with the both materials.

REFERENCES

- [1]. Richard F. Waughtal, Automobile weight reduction using High performance plastics.
- [2]. http://www.akamaiuniversity.us/PJST9_1_155.pdf
- [3]. George Fontes, H31 Booster rebuild & master cylinder, 1991 BMW 750iL, 2010
- [4]. Jeri S. Culp, Light weight brake system.
- [5]. C.J.Buynacek and W.L.Winterbottom, Aluminium master cylinders.
- [6]. www.beringer.fr
- [7]. Melior, Inc., Introduction to Brake Systems – Study guide.
- [8]. LEXUS Technical training, Master cylinder.
- [9]. Heinz-Heisler “advance vehicle technology”, second Edition, 2002, ISBN 07506 51318, Elsevier Butterworth-Heinemann pp. 494-496,
- [10]. R.K.Rajput(2007), “A textbook of Automobile Engineering”, First Edition, Laxmi Publication (P) Ltd., New Delhi – 110002.
- [11]. Julian happian- smith “An introduction to modern vehicle design”, First Edition, 2002, P.C. Brooks and D.C. Barton, ISBN 07506 50443, Elsevier Butterworth- Heinemann pp .157
- [12]. Tickoo Sham, Maini Deepak, “Pro/ENGINEER Wildfire 4.0 for Designers”, 2009, ISBN 1-932709-19-, CAD/CIM Technologies, USA.
- [13]. S.Kelley David., “Pro/ENGINEER Wildfire Instructor”, First Edition, 2005, ISBN 0-07-286520-2, McGraw-Hill Higher Education.
- [14]. “Getting Started with Pro/ENGINEER® Wildfire™”, April 2003, Parametric Technology Corporation (PTC).
- [15]. R.Chandrupatla Tirupathi and Belegundu Ashok D., “Introduction to Finite Element in Engineering”, Third Edition, 2002, Prentice-Hall India Ltd.